



Load ring - for welding **VLBS**

Safety instructions

This safety instruction/declaration of the manufacturer has to be kept on file for the whole lifetime of the product.
Translation of the Original instructions



Load ring **VLBS** - for welding



RUD Ketten
Rieger & Dietz GmbH u. Co. KG
D-73428 Aalen
Tel. +49 7361 504-1370
Fax +49 7361 504-1171
www.rud.com
sling@rud.com

RUD-Art.-Nr.: 8503014-EN / 03.015



EG-Konformitätserklärung

entsprechend der EG-Maschinenrichtlinie 2006/42/EG, Anhang II A und ihren Änderungen

Hersteller: **RUD Ketten**
Rieger & Dietz GmbH u. Co. KG
Friedensinsel
73432 Aalen

Hiermit erklären wir, dass die nachfolgend bezeichnete Maschine aufgrund ihrer Konzipierung und Bauart, sowie in der von uns in Verkehr gebrachten Ausführung, den grundlegenden Sicherheits- und Gesundheitsanforderungen der EG-Maschinenrichtlinie 2006/42/EG sowie den unten aufgeführten harmonisierten und nationalen Normen sowie technischen Spezifikationen entspricht.
Bei einer nicht mit uns abgestimmten Änderung der Maschine verliert diese Erklärung ihre Gültigkeit.

Produktbezeichnung: Lastbock VLBS

Folgende harmonisierten Normen wurden angewandt:

EN 12100 : 2011-03 EN 1677-1 : 2009-03

Folgende nationalen Normen und technische Spezifikationen wurden außerdem angewandt:

BGR 500, KAP2.8 : 2008-04 _____

Für die Zusammenstellung der Konformitätsdokumentation bevollmächtigte Person:
Reinhard Smetz, RUD Ketten, 73432 Aalen

Aalen, den 27.06.2014 Dr.-Ing. Arne Kriegsmann, (Prokurist/QMB) *Arne Kriegsmann*
Name, Funktion und Unterschrift Verantwortlicher



EC-Declaration of conformity

According to the EC-Machinery Directive 2006/42/EC, annex II A and amendments

Manufacturer: **RUD Ketten**
Rieger & Dietz GmbH u. Co. KG
Friedensinsel
73432 Aalen

We hereby declare that the equipment sold by us because of its design and construction, as mentioned below, corresponds to the appropriate, basic requirements of safety and health of the corresponding EC-Machinery Directive 2006/42/EC as well as to the below mentioned harmonized and national norms as well as technical specifications.
In case of any modification of the equipment, not being agreed upon with us, this declaration becomes invalid.

Product name: Load ring VLBS

The following harmonized norms were applied:

EN 12100 : 2011-03 EN 1677-1 : 2009-03

The following national norms and technical specifications were applied:

BGR 500, KAP2.8 : 2008-04 _____

Authorized person for the configuration of the declaration documents:
Reinhard Smetz, RUD Ketten, 73432 Aalen

Aalen, den 27.06.2014 Dr.-Ing. Arne Kriegsmann, (Prokurist/QMB) *Arne Kriegsmann*
Name, function and signature of the responsible person

User Instructions

- Reference should be made to German Standards accord. BGR 500/DGUV 100-500 or other country specific statutory regulations and inspections are to be carried out by competent persons only.
- Before installing and every use, visually inspect RUD lifting points, paying particular attention to any evidence of weld cracks, corrosion, wear, deformations, etc.

3. The material construction to which the lifting point will be attached should be of adequate strength to withstand forces during lifting without deformation. The contact areas must be free from impurities, oil, colour, ect.

The material of the forged welding block is S355J2+N (St52-3, 1.0577+N), B.S. 4360.50 D or AISI 1019

- The lifting points must be positioned on the load in such a way that movement is avoided during lifting.
 - For single leg lifts, the lifting point should be vertically above the centre of gravity of the load.
 - For two leg lifts, the lifting points must be equidistant to/above the centre of gravity of the load.
 - For three and four leg lifts, the lifting points should be arranged symmetrically around the centre of gravity in the same plane.

5. Load Symmetry:

The working load limits of individual RUD lifting points are calculated using the following formula and are based on symmetrical loading:

$$W_{LL} = \frac{G}{n \times \cos \beta}$$

W_{LL} = working load limit
 G = load weight (kg)
 n = number of load bearing legs
 β = angle of inclination of the chain to the vertical

The calculation of load bearing legs is as follows:

	symmetrical	asymmetrical
two leg	2	1
three / four leg	3	1

(see chart 1 + 5)

6. All fittings connected to the VLBS should be free moving. When connecting and disconnecting the lifting means (sling chain) pinches and impacts should be avoided. Damage of the lifting means caused by sharp edges should be avoided as well.

7. Suitability of temperature use: RUD-Lifting points VLBS are suitable for the temperature range from -20°C up to 400°C. For the use within the following temperature range, the WLL must be reduced by the following factors:

200°C up to 300°C: by -10 % and

300°C up to 400°C: by -25 %

The lifting points VLBS can be stress-relieved one-time in an unloaded condition, together with the load (e.g. welded construction): Temperature < 600°C (1100°F)

The evidence of the suitability of the used weld metal must be mentioned by the respective filler material manufacturer.

8. The places where the lifting points are fixed should be marked with colour.

9. At outdoor sites or in case of special danger of corrosion, the welds should only be designed as continuous, fillet welds. The HV weld at the VLBS guarantees a connection via the whole cross section of the material. This corresponds to a closed weld showing no signs of corrosion.

10. The distance lugs assist in achieving the correct root weld (approx. 3 mm = 0.1 inch). They may not be removed.

11. RUD-Lifting points must not be used under chemical influences such as acids, alkaline solutions and vapours e.g. in pickling baths or hot dip galvanising plants.

12. If the lifting points are used **exclusively** for lashing the value of the working load limit can be doubled. LC = 2 x WLL

13. After welding, an annual inspection or sooner if conditions dictate should be undertaken by a competent person examining the continued suitability. Also after damage and special occurrences.

Inspection criteria concerning paragraphs 2 and 13:

- The lifting point should be complete.
- The working load limit and manufacturers stamp should be clearly visible.
- Deformation of the component parts such as body and load ring.
- Mechanical damage, such as notches, particularly in high stress areas.
- Wear should be no more than 10 % of cross sectional diameter.
- Evidence of corrosion.
- Evidence of cracks.
- Cracks or other damages to the welding.

A non-adherence to this advice may result damages of persons and materials!











Method of lift										
Number of legs	1	1	2	2	2	2	2	3 and 4	3 and 4	3 and 4
Angle of inclination β	0°	90°	0°	90°	0-45°	45-60°	unsymm.	0-45°	45-60°	unsymm.
Factor	1	1	2	2	1.4	1	1	2.1	1.5	1
Type	max weight of load > G < in t									
 VLBS 1.5 t	1.5 t	1.5 t	3 t	3 t	2.1 t	1.5 t	1.5 t	3.15 t	2.25 t	1.5 t
VLBS 2.5 t	2.5 t	2.5 t	5 t	5 t	3.5 t	2.5 t	2.5 t	5.25 t	3.75 t	2.5 t
VLBS 4 t	4 t	4 t	8 t	8 t	5.6 t	4 t	4 t	8.4 t	6 t	4 t
VLBS 6.7 t	6.7 t	6.7 t	13.4 t	13.4 t	9.5 t	6.7 t	6.7 t	14 t	10 t	6.7 t
VLBS 10 t	10 t	10 t	20 t	20 t	14.0 t	10 t	10 t	21 t	15 t	10 t
VLBS 16 t	16 t	16 t	32 t	32 t	22.4 t	16 t	16 t	33.6 t	24 t	16 t

chart 1

The welding should only be carried out according to DIN EN ISO 9606-1 or AWS Standards by an authorized welder.

Welding sequence:

- Start tacking in the center of the welding block.
- Welding in stringer beads
- Before carrying out the top run, carefully clean the root.
- The welding process must not be interrupted for such a time that the welding block loses the welding temperature.
- Attention: Do not weld at the pink powder coated, heat treated load ring.

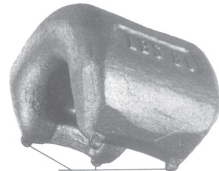

distance lugs for root welding

	weld		
	size	length	volume
VLBS 1.5 t	HV 5 + a 3	2 x 33 mm	approx. 1.2 cm ³
VLBS 2.5 t	HV 7 + a 3	2 x 40 mm	approx. 2.6 cm ³
VLBS 4 t	HV 8 + a 3	2 x 46 mm	approx. 3.2 cm ³
VLBS 6.7 t	HV 12 + a 4	2 x 60 mm	approx. 8.7 cm ³
VLBS 10 t	HV 16 + a 4	2 x 60 mm	approx. 15.5 cm ³
VLBS 16 t	HV 25 + a 6	2 x 90 mm	approx. 56 cm ³

chart 2

Welding seam definition:

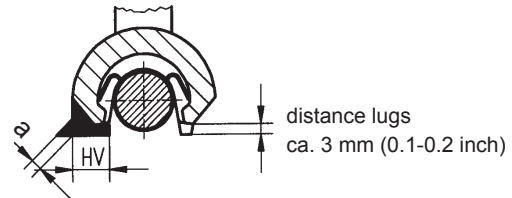

Welding procedure + Welding filler metals:

	Europe, USA, Asia, Australia, Africa
	Baustähle, niedrig legierte Stähle EN 10025 Mild steels, low alloyed steel
MIG / MAG (135) Gas shielded wire welding (135)	DIN EN ISO 14341: G4Si1 (G3Si1) z.B. PEGO G4Si1
E-Hand Gleichstrom (111, =) Stick Electrode direct current	DIN EN ISO 2560-A: E 42 6 B 3 2 H10 DIN EN ISO 2560-A: E 38 2 B 1 2 H10 z.B. PEGO B Spezial* / PEGO BR Spezial*
E-Hand (Wechselstrom 111, ~) Stick Electrode alternating current	DIN EN ISO 2560-A: E 38 2 RB 1 2 DIN EN ISO 2560-A: E 42 0 RC 1 1 z.B. PEGO RC 3 / PEGO RR B 7 Alternativ: DIN EN ISO 3581: E 23 12 2 L R 3 2 z.B. PEGO 309 MoL
WIG (141) TIG Tungsten arc welding	DIN EN ISO 636-A: W 3 Si 1 (W2 Si 1) DIN EN ISO 636-A: W 2 Ni 2 z.B. PEGO WSG 2 / PEGO WSG2Ni2

chart 3

* Stick dry weld

The specific processing informations of the welding fillers have to be attended.

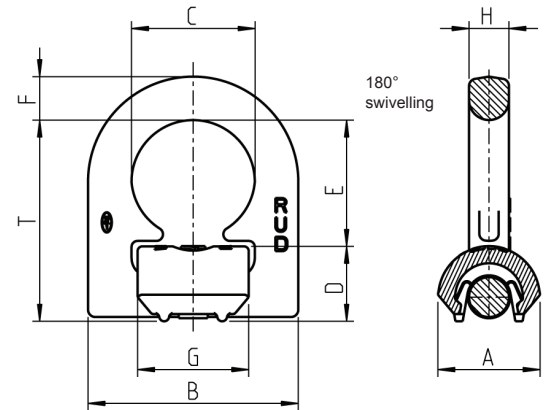

Type	WLL t	weight kg	A	B	C	D	E	F	G	H	T	ref-no.		D-ring	welding block	spring
												VLBS complete	VLBS without spring			
VLBS 1.5 t	1.5	0.35	33	66	38	25	40	14	33	14	65	7993035 *	7993115 *	7993028	7993021	7102228
VLBS 2.5 t	2.5	0.47	36	77	45	27	48	16	40	14	75	7994830 *	7995346 *	7994847	7994849	7102228
VLBS 4 t	4	0.8	42	87	51	31	52	18	46	16	83	7993036**	7993116**	7993029	7993022	7102232
VLBS 6.7 t	6.7	1.9	61	115	67	44	73	24	60	22	117	7993037***	7993117***	7993030	7993023	7102236
VLBS 10 t	10	2.9	75	129	67	55	71	26,5	60	26	126	7993040***	7993118***	7993031	7993024	7102133
VLBS 16 t	16	6.8	95	190	100	69	105	40	90	27	174	-	7993041	7993032	7993025	-

chart 4

* = package unit 20 pieces

** = package unit 10 pieces

*** = package unit 4 pieces

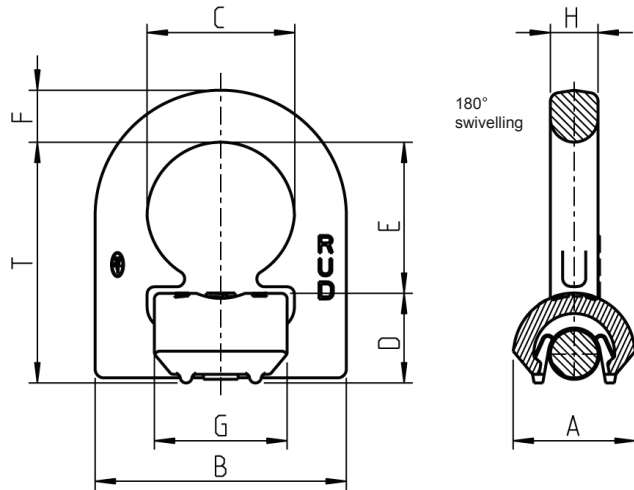
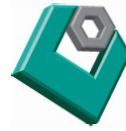

Type	WLL lbs	weight lbs	A	B	C	D	E	F	G	H	T	VLBS	
												complete	without spring
VLBS 1.5 t	3300	0.77	1 5/16"	2 19/32"	1 1/2"	1"	1 9/16"	9/16"	1 5/16"	17/32"	2 9/16"	7993035 *	7993115 *
VLBS 2.5 t	5500	1.03	1 13/32"	3 1/32"	1 3/4"	1 1/16"	1 7/8"	5/8"	1 19/32"	9/16"	3"	7994830 *	7995346 *
VLBS 4 t	8800	1.75	1 21/32"	3 7/16"	2"	1 7/32"	2 1/16"	23/32"	1 13/16"	21/32"	3 1/4"	7993036**	7993116**
VLBS 6.7 t	14750	4.2	2 13/32"	4 1/2"	2 5/8"	1 3/4"	2 7/8"	61/64"	2 3/8"	7/8"	4 5/8"	7993037***	7993117***
VLBS 10 t	22000	6.4	2 15/16"	5"	2 5/8"	2 1/8"	2 13/16"	1 1/16"	2 3/8"	1 3/64"	5"	7993040***	7993118***
VLBS 16 t	35200	15	3 3/4"	7 1/2"	3 15/16"	2 23/32"	4 1/8"	1 9/16"	3 9/16"	1 1/16"	6 7/8"	-	7993041

chart 5 * = package unit 20 pieces ** = package unit 10 pieces *** = package unit 4 pieces

Method of lift											
Number of legs	1	1	2	2	2	2	2	3 and 4	3 and 4	3 and 4	
Angle of inclination α	0°	90°	0°	90°	0-45°	45-60°	unsymm.	0-45°	45-60°	unsymm.	
Factor	1	1	2	2	1.4	1	1	2.1	1.5	1	
Type	max weight of load > G < in lbs										
	VLBS 1.5 t	3300	3300	6600	6600	4620	3300	3300	6930	4950	3300
	VLBS 2.5 t	5500	5500	11000	11000	7700	5500	5500	11550	8250	5500
	VLBS 4 t	8800	8800	17600	17600	12320	8800	8800	18500	13200	8800
	VLBS 6.7 t	14750	14750	29500	29500	20650	14750	14750	30980	22100	14750
	VLBS 10 t	22000	22000	44000	44000	30800	22000	22000	46200	33000	22000
	VLBS 16 t	35200	35200	70400	70400	49300	35200	35200	73920	52800	35200

chart 6